

A. Student outcomes

Assessment plan for the Electrical Engineering program is provided below. There is an assessment plan for each of the outcomes from a through k. The flow chart shows the course sequence critical to the specific outcome and the red boxes show the placement of the probes in the process. Any probe with a (B) signifies assessment at the beginning of the course and any probe with an (E) signifies assessment at the end of the course. While the assessment plan is provided outcome by outcome, the actual assessment data that follows the assessment plans is presented course by course.

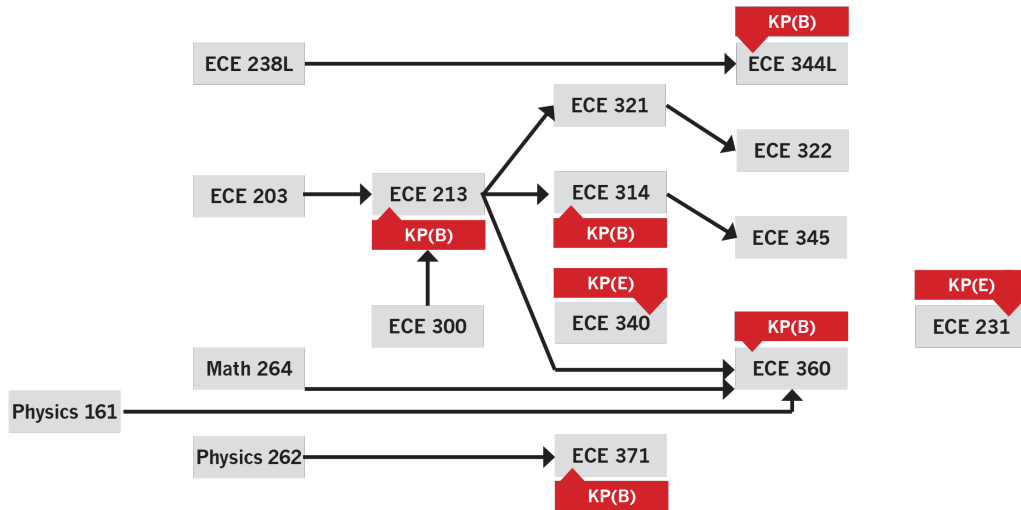

Figure 1: Assessment plan for outcome A.

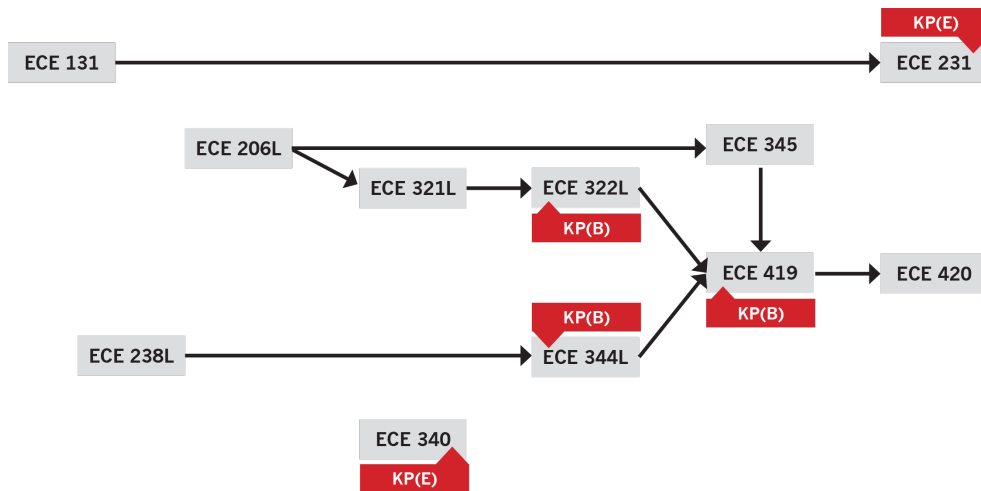

Figure 2: Assessment plan for outcome B.

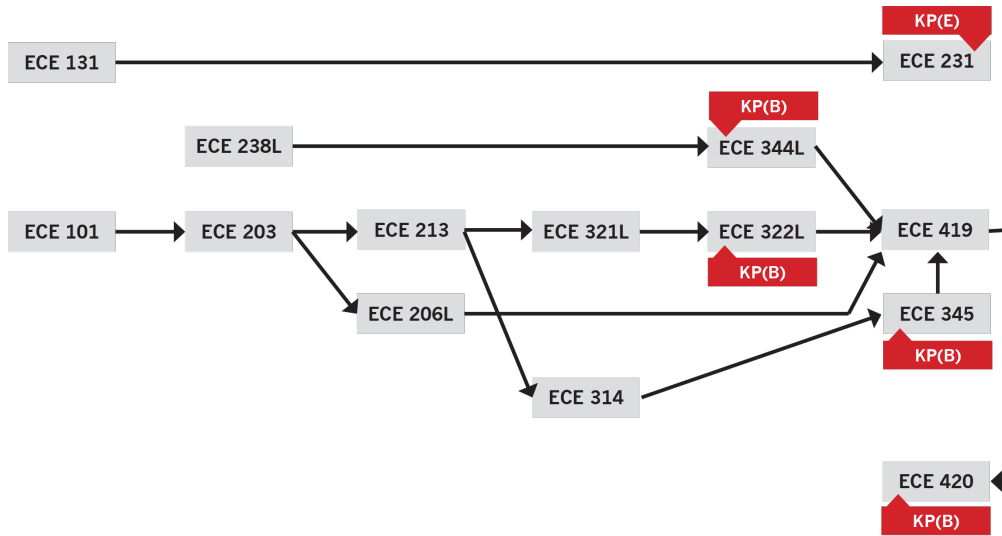

Figure 3: Assessment plan for outcome C.



Figure 4: Assessment plan for outcome D.

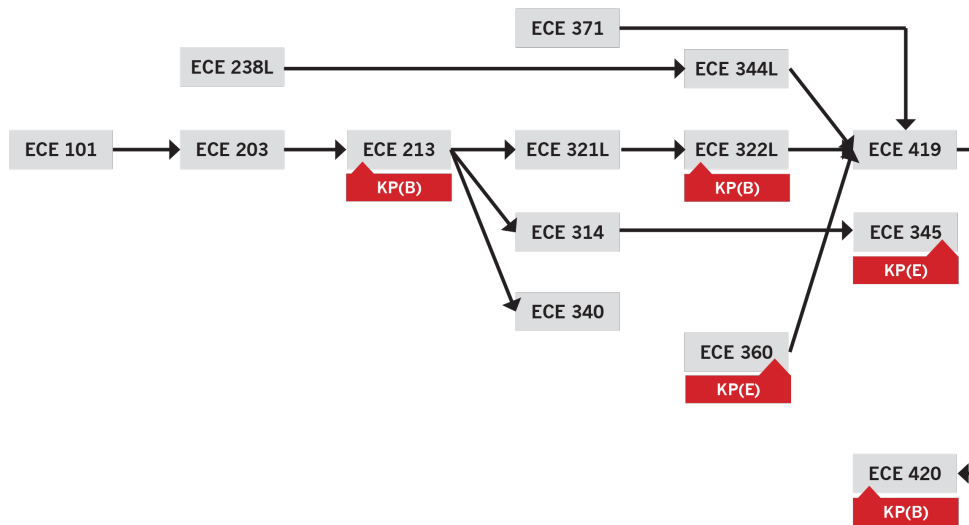

Figure 5: Assessment plan for outcome E.

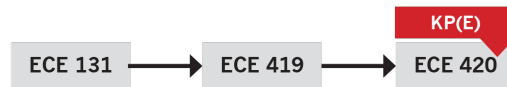

Figure 6: Assessment plan for outcome F.

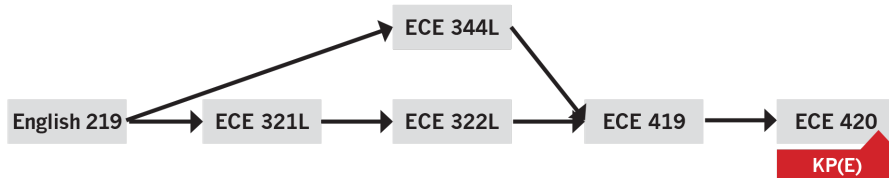

Figure 7: Assessment plan for outcome G.

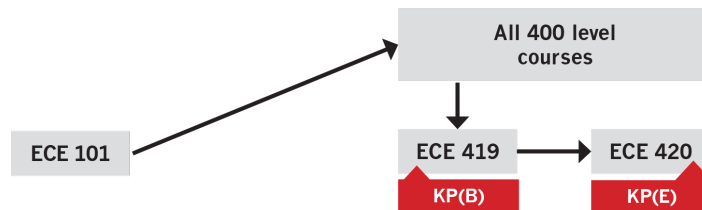

Figure 8: Assessment plan for outcome H.

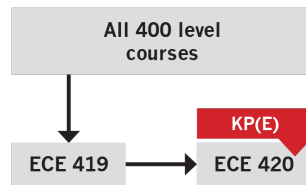

Figure 9: Assessment plan for outcome I.

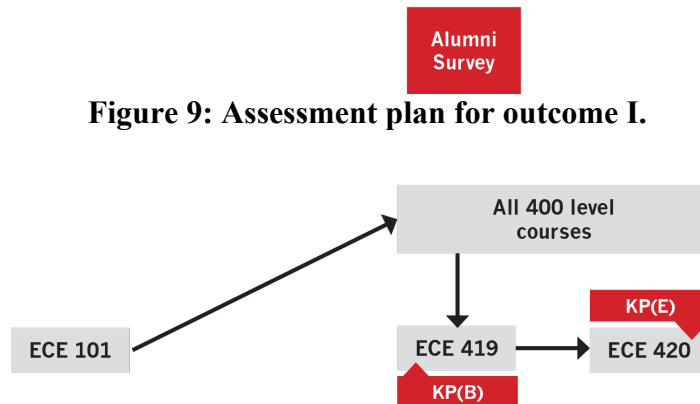

Figure 10: Assessment plan for outcome J.

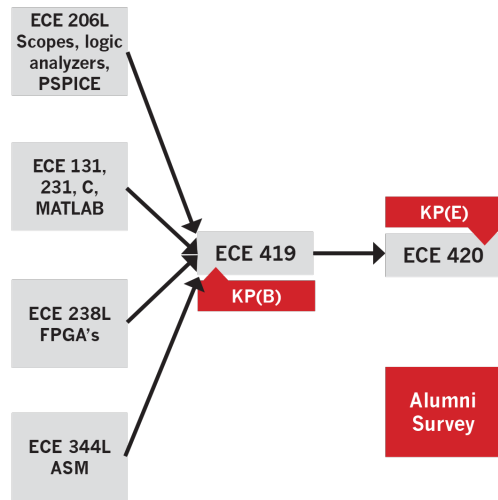

Figure 11: Assessment plan for outcome K.